



SHIFTER TRAILER

**SAFE, QUICK AND EFFICIENT
TRANSPORT OF HEAVY LOADS**

A product of AVT Europe

Shifter
Trailer

Shifter Trailer from AVT Europe Pioneer in heavy transport

At AVT Europe NV, we noticed the need for efficient transport solutions that adapt to different environments in plants and factories. That's why we went looking for a solution and came up with innovative new products, called Shifter!

Our Shifter transport solutions are flexible, easy to use and precise. **Shifter Trailer**, **Shifter Mono**, **Shifter Flex** and

Shifter Multi Flex all have their own special advantages.

'**Shifter Trailer**' is designed to be at its best in different types of warehouses.

So how does the **Shifter Trailer** work? The Shifter's Trailer is the perfect standard solution for heavy loads. It is accessible and trustworthy for anyone taking on modest projects.

Setup is a quick and easy procedure, offering more bang for your buck compared to a regular forklift while staying easy-to-use and cost-efficient.

Ask us about the advantages of the Shifter Trailer for your business!



**MOVING HEAVY PARTS, TOOLS, PRODUCTS - AND MORE -
FROM A TO B IN A SAFE AND FAST WAY!**

A Shifter suitable for each industry



Shown here are just some of the Shifter Trailer's possible applications. Through development of **custom-made variations** of the Shifter products, we're able to assist **every sector** in need of a solution.



Safety feature

Removable plug of the battery connection

Safety feature

Integrated lifting eyes



Safety feature

Dangerous parts are covered for safety

Safety feature

Lifting points for maintenance





01 Easy maneuvering

Precise movements ensure flexibility and accuracy.

02 Multi-purpose vehicle

The advanced system of Shifter Trailer can be used for the transport of pallets, containers, big bags, panels and more.



03 Minimal maintenance

All sides/compartments of Shifter are easy to reach. This makes our system easy to maintain. No need for overhead cranes or other tools.

04 Easy to use in hard to reach areas

Shifter Trailer comes in handy in areas where there are no overhead cranes available.



Driving methods

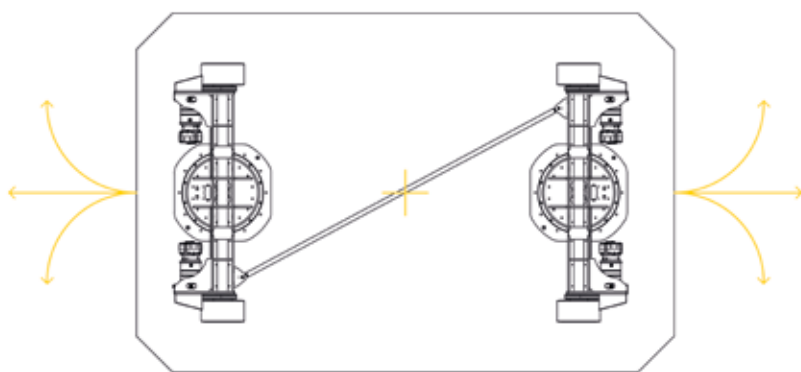
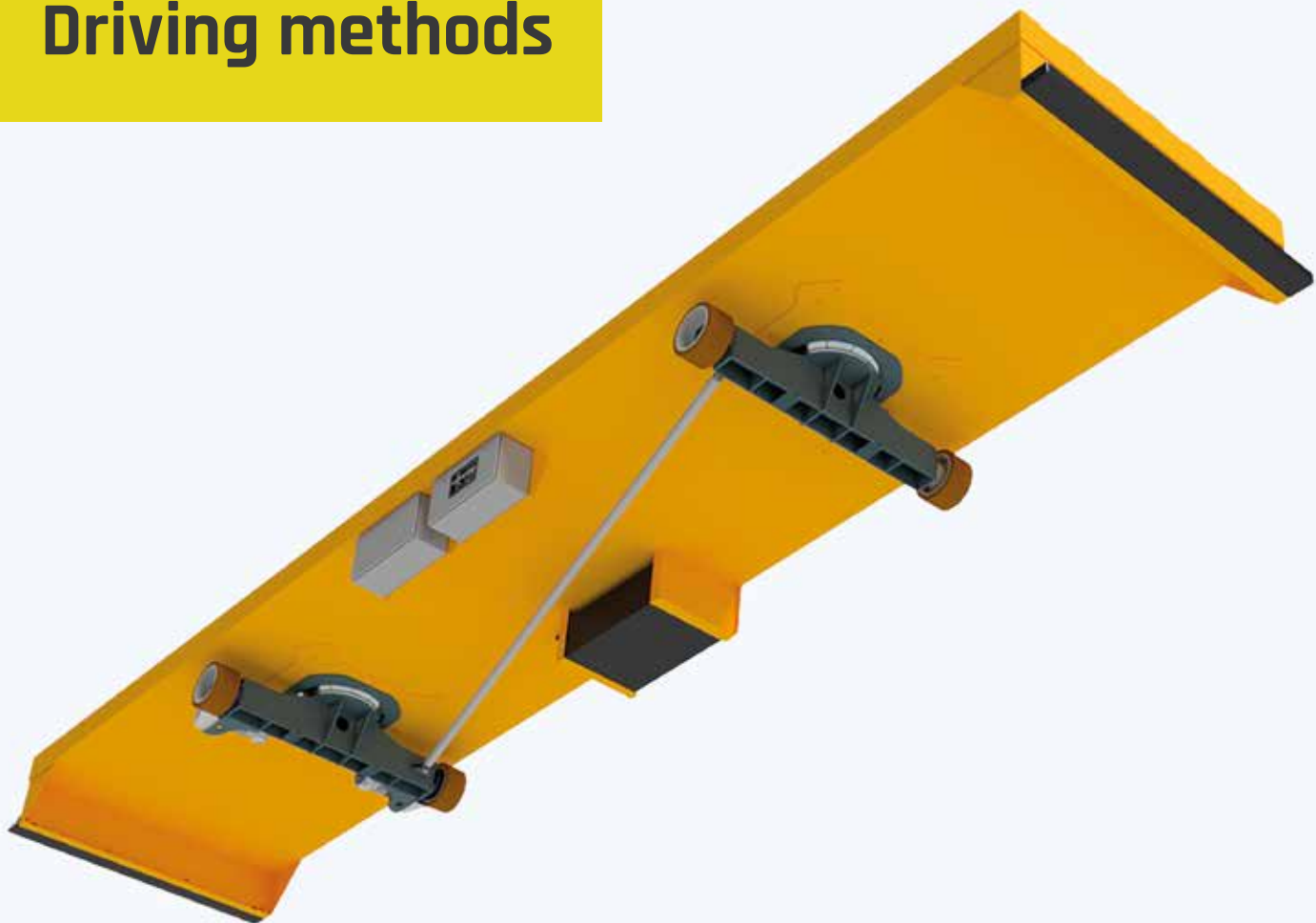

Driving direction

Shifter Trailer is able to move reverse, forward and in curves (left and right). The lateral movements you'd expect.

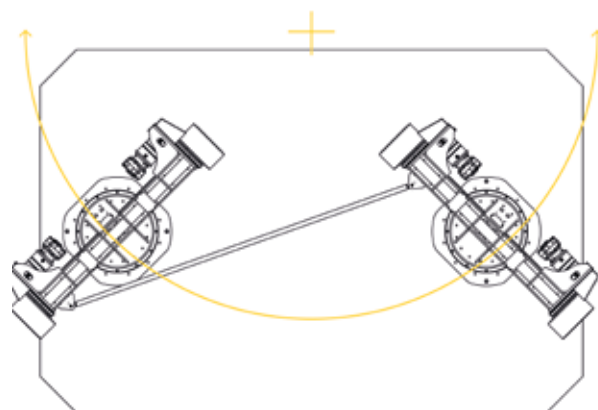

Rotation direction

The Shifter Trailer relies on designated points in the room to determine where to turn in advance - allowing for easy manoeuvring.

Included in every Shifter Trailer



Battery driven



Steering axle



4G connected



Remote controlled

Optional for your custom Shifter Trailer



ATEX proof package



LED indicators



Safety scanner



AGV ready



Safety bumper

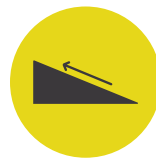

Slope



High speed package



More custom made solutions from AVT



Transport solutions



Robotics and automation

Contact us

-  info@a-vt.be
-  +32 3 546 39 00
-  www.shifter-avt.com
-  HQ
AVT Europe NV
Postbaan 65
BE-2910 Essen

Shifter is a brand of



Discover more solutions on
[//www.a-vt.be](http://www.a-vt.be)

